

DATE
REV

**MODEL AFFECTED:** 407

**SUBJECT:** SPANNER NUT P/N MS172244, INSPECTION OF

**HELICOPTERS AFFECTED:** 407 Helicopters serial number 53000 through 53900 and 53911 through 53994.

[407 helicopters serial number 53995 and subsequent will have the intent of this bulletin accomplished prior to delivery]

**COMPLIANCE:** **Part I:** Upon receipt of this bulletin.

**Part II:** At next scheduled inspection or as instructed in the "Accomplishment Instruction".

**DESCRIPTION:**

Bell Helicopter has received reports of corrosion on spanner nut MS172244. This corrosion has been noticed on installed as well as newly received nuts due to omission of phosphate treatment during manufacturing process.

PART I of this bulletin introduces spanner nut P/N 90-118-4 as a direct replacement for nut P/N MS172244.

PART II of this bulletin provides instructions for spanner nuts P/N MS172244 that are installed on the Helicopter.

**APPROVAL:**

The engineering design aspects of this bulletin are Transport Canada Civil Aviation (TCCA) approved.

**MANPOWER:**

No additional man-hours are required to accomplish Part I and approximately 2.0 man-hours are required to complete Part II of this bulletin if not accomplished during scheduled maintenance. Man-hours are based on hands-on time, and may vary with personnel and available facilities.

**WARRANTY:**

Owners / Operators of Bell Helicopters who comply with the instructions in of this Bulletin will be eligible to receive a credit towards the purchase of a replacement nut part number 90-118-4.

To receive this credit:

- Comply with the instructions contained in this Bulletin no later than the **31 July 2010**.
- Purchase replacement part form a Bell approved source.
- Submit an MMIR to the Bell Warranty Department.

Customers who fail to comply with the instructions in this Bulletin before the **31 July 2010** are not eligible for the special warranty credit listed above. (There is no labor associated with this bulletin).

**MATERIALS:**

**Required Material:**

The following material is required for the accomplishment of this bulletin and may be obtained through your Bell Helicopter Textron Supply Center.

<b><u>Part Number</u></b>	<b><u>Nomenclature</u></b>	<b><u>Quantity</u></b>
90-118-4	Nut	As required
MS172209	Washer	As required

**Consumable Material:**

The following material is required to accomplish this bulletin, however this material is considered consumable (bench stock) material and may not require ordering depending on the operators consumable material stock levels. This material may be obtained through your Bell Helicopter Textron Supply Center.

<u>Part Number</u>	<u>Nomenclature</u>	<u>Quantity</u>	<u>Reference</u>	<u>NOTE</u>
TT-N-95,TYII 1GAL	Aliphatic Naphtha	As required	C-305	
MIL-C-16173,GR1 2OZ	Corrosion Protection Compound	As required	C-101	1

**NOTE:**

1. As an alternate use THIXOGREASE (C-561)

**SPECIAL TOOLS:**

None required

**WEIGHT AND BALANCE:**

Not affected

**ELECTRICAL LOAD DATA:**

Not affected

**REFERENCES:**

BHT-407-MM Maintenance Manual  
BHT-ALL-SPM Standard Practices Manual

**PUBLICATIONS AFFECTED:**

BHT-407-IPB Chapter 65

**ACCOMPLISHMENT INSTRUCTIONS:**

**PART I: Spanner nut in spare inventory.**

-NOTE-

Dark gray color appearance is the indicator of phosphate coating.

1. Examine spanner nut MS172244 for evidence of phosphate coating.
  - a. If the nut does not have the phosphate coating, discard the nut and replace with 90-118-4 or MS172244 nut that has phosphate coating. Evidence of corrosion is an indication that the phosphate coating was omitted.
  - b. If no corrosion is found and nut has phosphate coating, it is serviceable. Use the existing stock till depleted.

**PART II: Spanner nut installed on the helicopter.**

1. Gain access to oil cooler blower shaft assembly (Refer to Detail A, Fig 1).

-NOTE-

Do not allow Aliphatic Naphtha to contact the bearing.

2. Clean forward and aft nuts (3) using Aliphatic Naphtha (C-305).
3. Visually inspect forward and aft spanner nuts (3) for evidence of corrosion.
  - a. If surface corrosion is found, remove and replace with nut 90-118-4 or phosphate coated nut MS172244 (Refer to BHT-407-MM-7 Chapter 65). If the nut can not be replaced immediately, apply corrosion preventive compound (C-101). Replace the nut when ever convenient.
  - b. If pitting corrosion is found, remove and replace immediately with nut 90-118-4 or phosphate coated nut MS172244 (Refer to BHT-407-MM-7 Chapter 65).

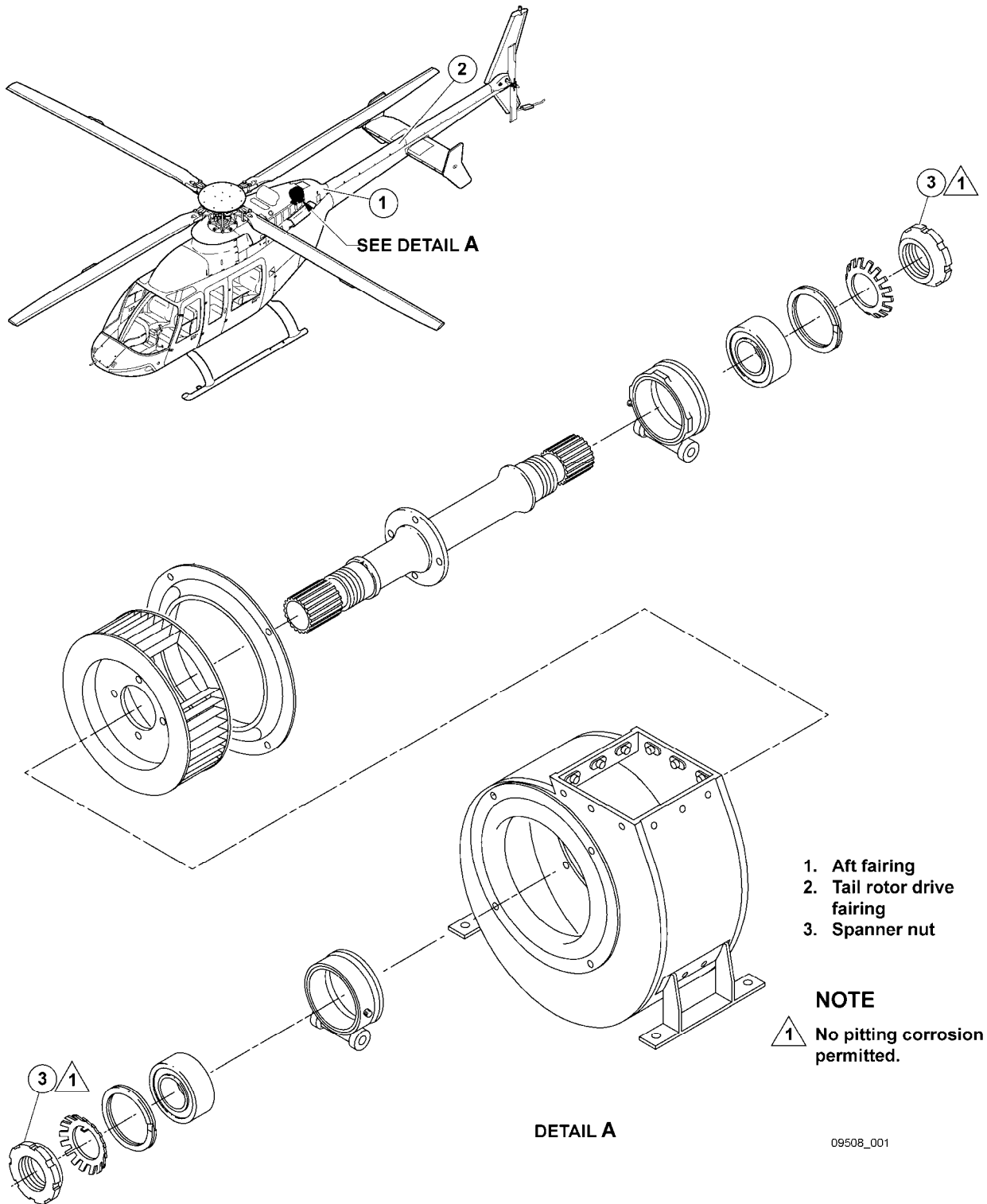

Figure 1. Oil cooler blower assembly