



A Textron Company

TECHNICAL BULLETIN

429-11-20
11 November 2011

MODEL AFFECTED: 429

SUBJECT: ELECTRICAL BONDING BETWEEN CROSSHEAD ASSEMBLY P/N 429-012-110-101 AND PLATE P/N 429-012-111-101, IMPROVEMENT OF.

HELICOPTERS AFFECTED: Serial number 57001 through 57067.

Serial numbers 57068 and subsequent will have the intent of this bulletin accomplished prior to delivery.

COMPLIANCE: At the next 50 hours inspection

DESCRIPTION:

Bell Helicopter has determined that radio interference may occur due to the loss of conductivity between the tail rotor crosshead assembly P/N 429-012-110-101 and drive plate P/N 429-012-111-101.

This Technical Bulletin provides the means to improve the electrical bonding between these two parts in order to rectify this issue. Compliance with this bulletin will make crosshead assembly P/N 429-012-110-101 equivalent to P/N 429-012-110-105.

APPROVAL:

The engineering design aspects of this bulletin are Transport Canada Civil Aviation (TCCA) approved.

CONTACT INFO:

For any questions regarding this bulletin, please contact:

Bell Helicopter Product Support Engineering - Intermediate Helicopters
Tel: 450-437-2077 / 1-800-463-3036 / pseinter@bellhelicopter.textron.com

MANPOWER:

Approximately 3.0 man-hours are required to complete this bulletin. This estimate is based on hands-on time, and may vary with personnel and facilities available.

WARRANTY:

There is no warranty credit applicable for parts or labor associated with this bulletin.

MATERIAL:**Consumable Material:**

The following material is required to accomplish this bulletin, but may not require ordering, depending on the operator's consumable material stock levels. This material may be obtained through your Bell Helicopter Textron Supply Center.

| <u>Part Number</u> | <u>Nomenclature</u> | <u>Qty</u> | <u>Reference *</u> |
|-----------------------|---------------------|------------|--------------------|
| Turco 5351(T-5469) | Paint remover | A/R** | C-436 |
| MIL-PRF-81322 Grade A | Grease | A/R** | C-001 |
| MIL-PRF-16173 Grade 1 | CPC | A/R** | C-101 |
| MIL-PRF-16173 Grade 2 | CPC | A/R** | C-104 |
| AMS-S-8802 Class B2 | Sealant | A/R** | C-431 |
| Isopropyl Alcohol | Isopropyl alcohol | A/R** | C-385 |

* C-XXX numbers refer to the consumables list in BHT-ALL-SPM Standard Practices Manual

** As required

SPECIAL TOOLS:

None required

WEIGHT AND BALANCE:

Not affected

ELECTRICAL LOAD DATA:

Not affected

REFERENCES:

BHT-429-MM Maintenance Manual, Chapter 67

BHT-ALL-SPM Standard Practices Manual, Chapter 4

PUBLICATIONS AFFECTED:

BHT-429-MM Maintenance Manual, Chapter 67

ACCOMPLISHMENT INSTRUCTIONS:

1. Remove drive plate (3, figure 1) per BHT-429-MM chapter 67.
2. Verify that there is no paint as shown in figure 2 on the crosshead (4, figure 1) and the drive plate (3, figure 1).
3. If no paint is present, reinstall drive plate (3) per BHT-429-MM chapter 67 and make an entry in helicopter historical service records indicating compliance with this Technical Bulletin.
4. If paint is present, remove crosshead (4, figure 1) per BHT-429-MM chapter 67.

CAUTION

Only non chlorinated hydrocarbon paint removers should be used. If chlorinated hydrocarbon paint remover is used, part should be alkaline cleaned.

5. Remove the paint from affected surfaces of crosshead (4) assembly and drive plate (3) with paint remover (C-436). Refer to Figure 2 for areas that must be free of paint. Refer to BHT-ALL-SPM Chapter 4 for paint stripping details.
6. Neutralize paint remover by rinsing crosshead (4) and drive plate (3) thoroughly with water. Carefully dry parts using low pressure filtered compressed air.
7. Clean crosshead (4) and plate (3) with isopropyl alcohol (C-385).
8. Install crosshead (4) and drive plate (3) per BHT-429-MM chapter 67.
9. Make an entry in helicopter historical service records indicating compliance with this Technical Bulletin.

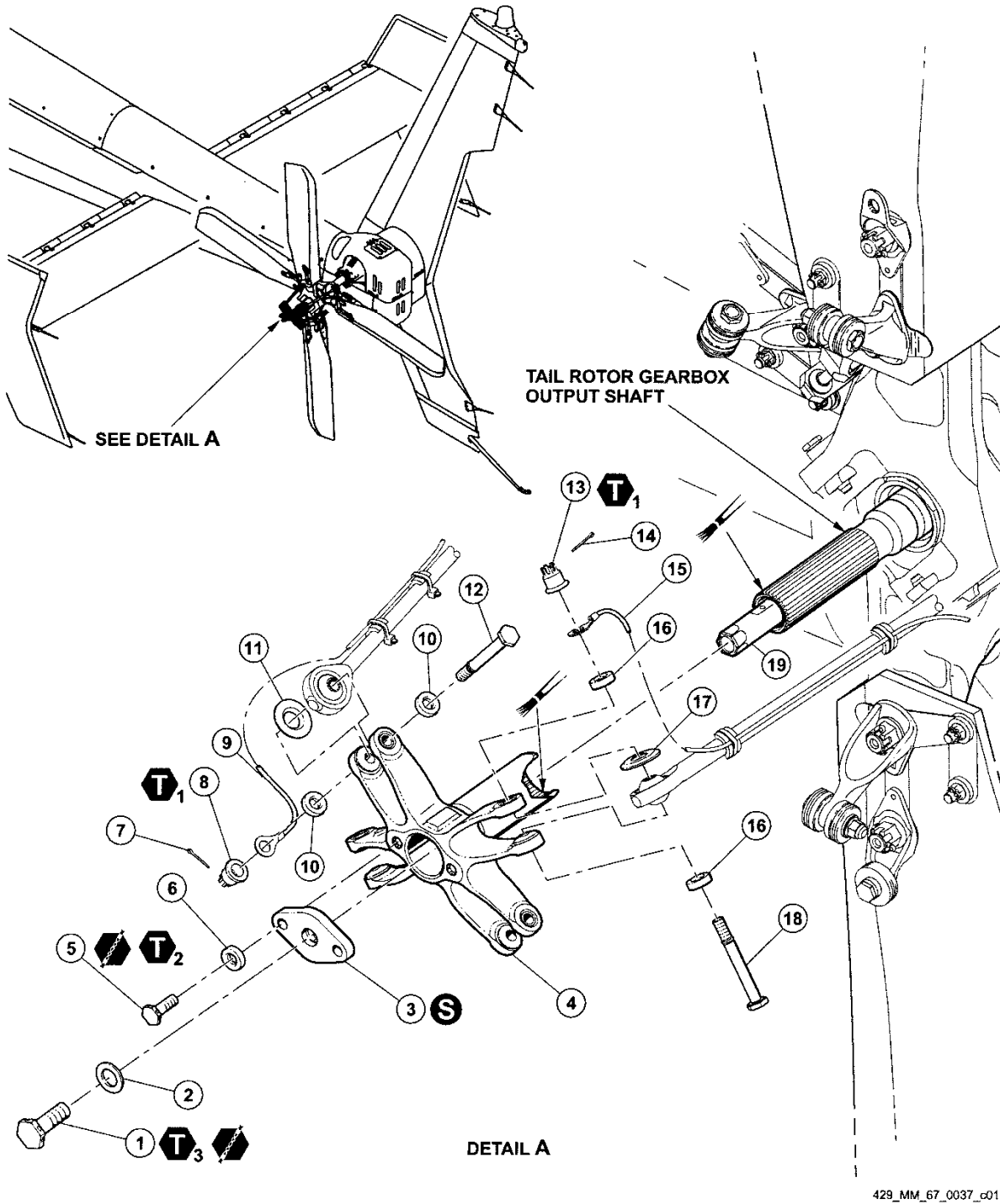

Figure 1. Crosshead Assembly – Removal and Installation (Sheet 1 of 2)

1. Bolt
2. Washer
3. Drive plate
4. Crosshead assembly
5. Bolt
6. Washer
7. Cotter pin
8. Nut
9. Jumper assembly
10. Washer
11. Washer
12. Bolt
13. Nut
14. Cotter pin
15. Jumper assembly
16. Washer
17. Washer
18. Bolt
19. Tail rotor control tube

 **G**₁ CORROSION PREVENTIVE COMPOUND (C-104) 

 **G**₂ CORROSION PREVENTIVE COMPOUND (C-101) 

 GREASE (C-001)

 LOCKWIRE (C-405)

 **S** SEALANT (C-308)

 **T**₁ 50 TO 70 IN-LBS
(5.65 TO 7.91 Nm)

 **T**₂ 75 TO 95 IN-LBS
(8.47 TO 10.73 Nm)

 **T**₃ 39 TO 43 FT-LBS
(53 TO 58 Nm)

NOTES

 **1** Apply a coating of corrosion preventive compound (C-104) to all bolt shanks prior to installation. Do not apply corrosion preventive compound to bolt threads.

 **2** Apply a coating of corrosion preventive compound (C-101) to all bolt heads, washers, nuts and exposed threads after installation.

429_MM_67_0044

Figure 1. Crosshead Assembly – Removal and installation (Sheet 2 of 2)

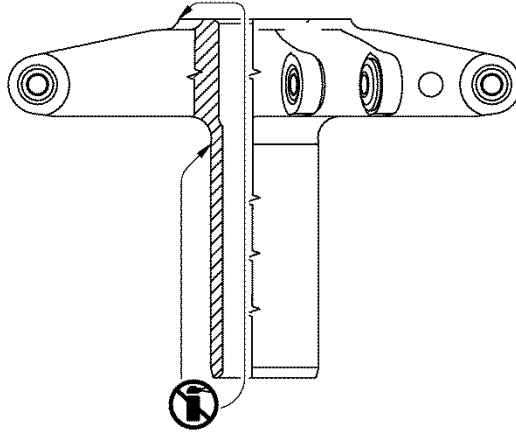

CROSSHEAD ASSEMBLY
429-012-110-101

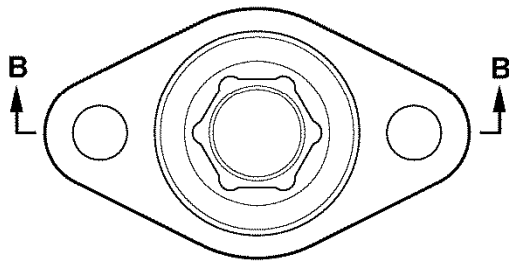

VIEW A

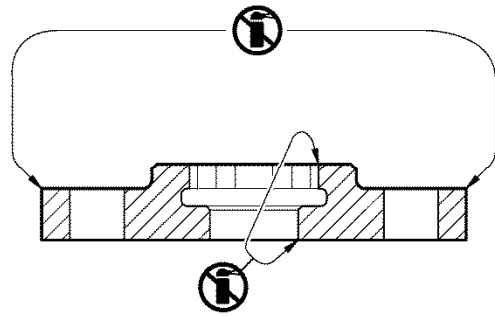

SECTION B-B

DRIVE PLATE
429-012-111-101

11517_001_c01

 **NO ORGANIC FINISH**

Figure 2. Crosshead/ Drive Plate – Paint removal area